

LISTINO AL - 2022

a1

www.attrezzaturearredi.it

ITALIA

LISTINO PREZZI

LAVABICCHIERI - LAVASTOVIGLIE - LAVASTOVIGLIE A CAPOTE
LAVASTOVIGLIE A TRAINO - LAVAOGGETTI - CESTI E ACCESSORI

GLASSWASHER and DISHWASHER

- 2 AL230X
glasswasher
- 4 AL240X
glasswasher
- 6 AL240E
glasswasher
- 8 AL250X
glasswasher
- 10 AL260X
dishwasher
- 12 AL260E
dishwasher
- 14 AL260XL
dishwasher
- 16 AL260EL
dishwasher
- 18 AL280X
hoodtype
- 20 AL280E
hoodtype
- 22 Tables for Hood-type
Tablas para Lavavajillas de cúpula - Tavoli per Capot

RACK-CONVEYOR

- 26 AL101XL
rackconveyor
- 28 AL102XL
rackconveyor
- 30 Accessories for Rack-Conveyor
Accesorios para lavavajillas de arrastre - Accessori
per Traino

POTWASHER

- 40 AL8XLE
utensilwasher
- 42 AL9XLE
utensilwasher
- 44 AL9HXLE
utensilwasher



RACK and ACCESSORIES

- 48 Rack - Cestas - Cesti
- 59 Detergent dispenser and drain pump - Dosificador de
detergente y bomba de desague - Dosatori e detergenti
- 60 Water softner - Suavizador - Addolcitore
- 61 Detergents - Detergencia - Detergenza
- 63 Conditions of sales - Condiciones de venta - Condizioni
di vendita

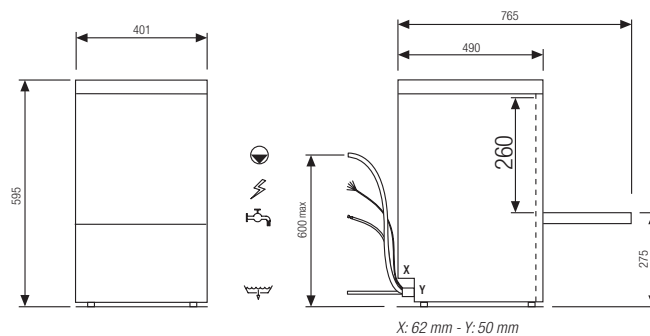
AL230X







Model - Modelo - Modello	Cod.	€
AL230X	917844	1.480,00
AL230XD	917845	1.590,00
AL230XR	917903	1.530,00

Standard Equipment - Equipamiento - Dotazioni	Cod.
 n. 2	781038
 n. 1	780139
 n. 2 (round rack version - versión cesta redonda - versione con cesto rotondo)	706147

* D: peristaltic detergent dispenser - dosificador de detergente peristáltico - dosatore detergente peristaltico
 **R: round rack version - versión cesta redonda - versione con cesto rotondo

Technical data - Datos técnicos - Dati tecnici



Dimension - Dimensiones - Dimensioni		cm	40.1x49x59.5
Door opening height - Altura puerta - Apertura porta		cm	26
Dish max. height - Altura máxima plato - Altezza max piatto		cm	-
Glass max. height - Altura máxima vaso - Altezza max bicchiere		cm	25
Washing cycle - Ciclo de lavado - Ciclo di lavaggio		sec.	120
Rack - Cesta - Cesto		cm	35x35 - Ø35
Water consumption - Consumo de agua - Consumo acqua		L/cycle - L/ciclo - L/ciclo	2
Wash pump - Bomba propulsora - Pompa di lavaggio		kW	0.15
		L	7
Tank - Cuba - Vasca		kW	0.6
		°C	60
		L	2.6
Booster - Calderín - Boiler		kW	2.6
		°C	65
Peristaltic rinse dispenser - Dosificador peristáltico de abrillantador - Dosatore brillantante peristaltico			✓

Optional	Cod.	€	Installed power Potencia instalada - Potenza Installata	Amp.	kW
Drain pump Bomba de desagüe - Pompa scarico	999354	195,00	230 V - 50 Hz - 1N	16	3.5
Detergent dispenser Dosificador de detergente - Dosatore detergente	999347	235,00	Available - Disponibile - Disponibile		
Composite tank strainer - Filtro cuba en material compuesto - Filtri vasca in materiale composito	121988	51,00	230 V - 60 Hz - 1N	16	3.5

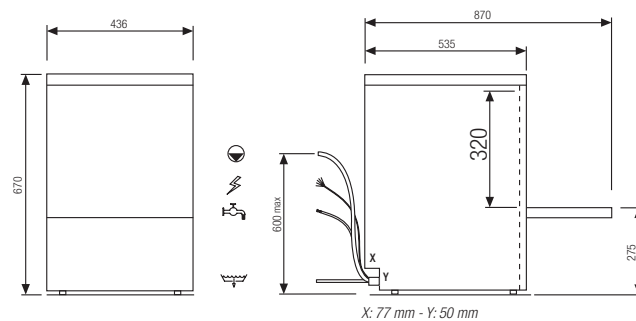
AL240X



Model - Modelo - Modello	Cod.	€
AL240X	917846	1.760,00
AL240XD	917847	1.870,00
AL240XDP	917905	2.000,00
AL240XR	917904	1.810,00
AL240XD (60hz)	918422	1.820,00







Standard Equipment - Equipamiento - Dotazioni		Cod.
	n. 2	780133
	n. 1	780139
	n. 2 (round rack version - versión cesta redonda - versione con cesto rotondo)	706148

* D: peristaltic detergent dispenser - dosificador de detergente peristáltico - dosatore detergente peristáltico

**DP: peristaltic detergent dispenser and drain pump - dosi cador de detergente peristáltico y bomba de desagüe - dosatore detergente peristáltico e pompa scarico

***R: round rack version - versión cesta redonda - versione con cesto rotondo

Technical data - Datos técnicos - Dati tecnici



Dimension - Dimensiones - Dimensioni		cm	43.6x53.5x67
Door opening height - Altura puerta - Apertura porta		cm	32
Dish max. height - Altura máxima plato - Altezza max piatto		cm	30
Glass max. height - Altura máxima vaso - Altezza max bicchiere		cm	30
Washing cycle - Ciclo de lavado - Ciclo di lavaggio		sec.	120
Rack - Cesta - Cesto		cm	39x39 - Ø39
Water consumption - Consumo de agua - Consumo acqua		L/cycle - L/ciclo - L/ciclo	2
Wash pump - Bomba propulsora - Pompa di lavaggio		kW	0.2
		L	8
Tank - Cuba - Vasca		kW	0.6
		°C	60
		L	2.6
Booster - Calderín - Boiler		kW	2.6
		°C	65
Peristaltic rinse dispenser - Dosificador peristáltico de abrillantador - Dosatore brillantante peristaltico			✓

Optional	Cod.	€	Installed power Potencia instalada - Potenza Installata	Amp.	kW
Drain pump Bomba de desagüe - Pompa scarico	999354	195,00	230 V - 50 Hz - 1N	16	3.5
Detergent dispenser Dosificador de detergente - Dosatore detergente	999347	235,00	230 V - 60 Hz - 1N	16	3.5
Composite tank strainer - Filtro cuba en material compuesto - Filtri vasca in materiale composito	121989	51,00			

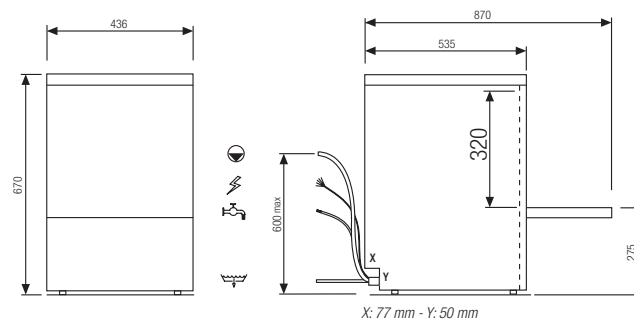
AL240E



Model - Modelo - Modello	Cod.	€
AL240E	918442	1.890,00

Standard Equipment - Equipamiento - Dotazioni		Cod.
	n. 2	780133
	n. 1	780139
	n. 2 (round rack version - versión cesta redonda versione con cesto rotondo)	706148

Technical data - Datos técnicos - Dati tecnici



Dimension - Dimensiones - Dimensioni		cm	43.6x53.5x67
Door opening height - Altura puerta - Apertura porta		cm	32
Dish max. height - Altura máxima plato - Altezza max piatto		cm	30
Glass max. height - Altura máxima vaso - Altezza max bicchiere		cm	30
Washing cycle - Ciclo de lavado - Ciclo di lavaggio		sec.	60 - 120 - 150 - 
Rack - Cesta - Cesto		cm	39x39 - Ø39
Water consumption - Consumo de agua - Consumo acqua		L/cycle - L/ciclo - L/ciclo	2
Wash pump - Bomba propulsora - Pompa di lavaggio		kW	0.2
		L	8
Tank - Cuba - Vasca		kW	0.6
		°C	60
		L	2.6
Booster - Calderín - Boiler		kW	2.6
		°C	65 (80)
Peristaltic rinse dispenser - Dosificador peristáltico de abrillantador - Dosatore brillantante peristaltico			✓
Peristaltic detergent dispenser - Dosificador peristáltico de detergente - Dosatore detergente peristaltico			✓

Optional	Cod.	€	Installed power Potencia instalada - Potenza Installata	Amp.	kW
Drain pump Bomba de desagüe - Pompa scarico	999354	195,00	230 V - 50 Hz - 1N	16	3.5
Composite tank strainer - Filtro cuba en material compuesto - Filtri vasca in materiale composito	121989	51,00	Available - Disponibile - Disponibile		
			230 V - 60 Hz - 1N	16	3.5

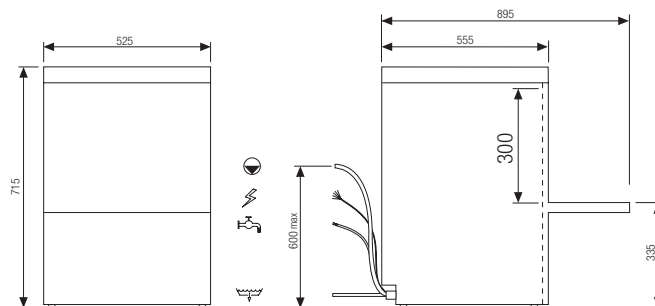
AL250X









Model - Modelo - Modello	Cod.	€
AL250X	917848	2.370,00
AL250XD	917849	2.480,00

Standard Equipment - Equipamiento - Dotazioni		Cod.
	n. 1	780129
	n. 1	780128
	n. 1	780139

* D: peristaltic detergent dispenser - dosificador de detergente peristáltico - dosatore detergente peristaltico

Technical data - Datos técnicos - Dati tecnici



Dimension - Dimensiones - Dimensioni		cm	52.5x55.5x71.5
Door opening height - Altura puerta - Apertura porta		cm	30
Dish max. height - Altura máxima plato - Altezza max piatto		cm	28
Glass max. height - Altura máxima vaso - Altezza max bicchiere		cm	28
Washing cycle - Ciclo de lavado - Ciclo di lavaggio		sec.	120
Rack - Cesta - Cesto		cm	45x45
Water consumption - Consumo de agua - Consumo acqua		L/cycle - L/ciclo - L/ciclo	2
Wash pump - Bomba propulsora - Pompa di lavaggio		kW	0.2
		L	14
Tank - Cuba - Vasca		kW	0.6
		°C	60
		L	2.6
Booster - Calderín - Boiler		kW	2.6
		°C	65 - 80
Peristaltic rinse dispenser - Dosificador peristáltico de abrillantador - Dosatore brillantante peristaltico			✓

Optional	Cod.	€	Installed power Potencia instalada - Potenza Installata	Amp.	kW
Drain pump Bomba de desagüe - Pompa scarico	999357	235,00	230 V - 50 Hz - 1N	16	3.5
Detergent dispenser Dosificador de detergente - Dosatore detergente	999347	235,00	Available - Disponible - Disponibile		
			230 V - 60 Hz - 1N	16	3.5

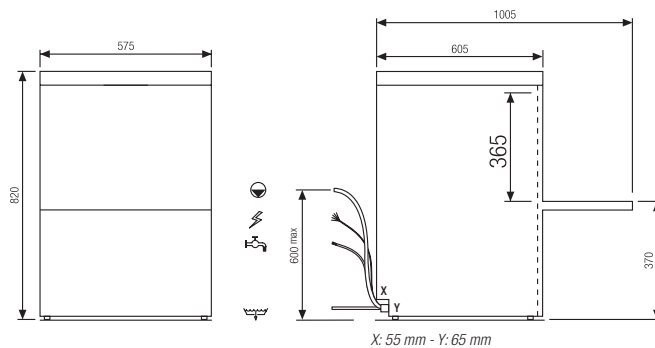
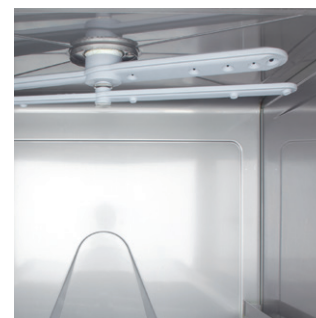
AL260X



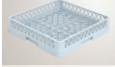





Model - Modelo - Modello	Cod.	€
AL260X	917850	2.480,00
AL260XD	917851	2.590,00
AL260XD (60Hz)	918423	2.480,00

Standard Equipment - Equipamiento - Dotazioni	Cod.
	n. 1 780131
	n. 1 780132
	n. 1 780139

* D: peristaltic detergent dispenser - dosificador de detergente peristáltico - dosatore detergente peristaltico

Technical data - Datos técnicos - Dati tecnici



Dimension - Dimensiones - Dimensioni		cm	57.5x60.5x82
Door opening height - Altura puerta - Apertura porta		cm	36.5
Dish max. height - Altura máxima plato - Altezza max piatto		cm	36.5
Glass max. height - Altura máxima vaso - Altezza max bicchiere		cm	32.5
Washing cycle - Ciclo de lavado - Ciclo di lavaggio		sec.	60 - 120
Rack - Cesta - Cesto		cm	50x50
Water consumption - Consumo de agua - Consumo acqua		L/cycle - L/ciclo - L/ciclo	2.4
Wash pump - Bomba propulsora - Pompa di lavaggio		kW	0.5
		L	20
Tank - Cuba - Vasca		kW	2.1
		°C	60
		L	6
Booster - Calderín - Boiler		kW	3
		°C	80
Peristaltic rinse dispenser - Dosificador peristáltico de abrillantador - Dosatore brillantante peristaltico			✓

Optional	Cod.	€	Installed power Potencia instalada - Potenza Installata	Amp.	kW
Drain pump Bomba de desagüe - Pompa scarico	999342	235,00	230 V - 50 Hz - 1N	16	3.5
Detergent dispenser Dosificador de detergente - Dosatore detergente	999347	235,00	230 V - 60 Hz - 1N	16	3.5
Composite tank strainer - Filtro cuba en material compuesto - Filtri vasca in materiale composito	121990	51,00			

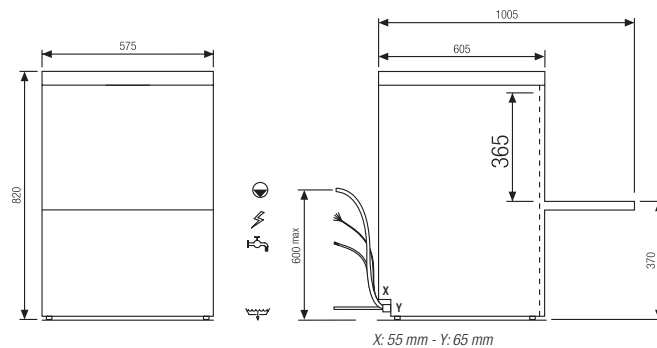
AL260E



Model - Modelo - Modello	Cod.	€
AL260E	918443	2.640,00

Standard Equipment - Equipamiento - Dotazioni		Cod.
	n. 1	780131
	n. 1	780132
	n. 1	780139

Technical data - Datos técnicos - Dati tecnici



Dimension - Dimensiones - Dimensioni		cm	57.5x60.5x82
Door opening height - Altura puerta - Apertura porta		cm	36.5
Dish max. height - Altura máxima plato - Altezza max piatto		cm	36.5
Glass max. height - Altura máxima vaso - Altezza max bicchiere		cm	32.5
Washing cycle - Ciclo de lavado - Ciclo di lavaggio		sec.	60 - 120 - 150 - ∞ -
Rack - Cesta - Cesto		cm	50x50
Water consumption - Consumo de agua - Consumo acqua		L/cycle - L/ciclo - L/ciclo	2.4
Wash pump - Bomba propulsora - Pompa di lavaggio		kW	0.5
		L	20
Tank - Cuba - Vasca		kW	2.1
		°C	60
		L	6
Booster - Calderín - Boiler		kW	3
		°C	80
Peristaltic rinse dispenser - Dosificador peristáltico de abrillantador - Dosatore brillantante peristaltico			✓
Peristaltic detergent dispenser - Dosificador peristáltico de detergente - Dosatore detergente peristaltico			✓

Optional	Cod.	€	Installed power Potencia instalada - Potenza Installata	Amp.	kW
Drain pump Bomba de desagüe - Pompa scarico	999342	235,00	230 V - 50 Hz - 1N	16	3.5
Composite tank strainer - Filtro cuba en material compuesto - Filtri vasca in materiale composito	121990	51,00	Available - Disponibile - Disponibile		
			230 V - 60 Hz - 1N	16	3.5

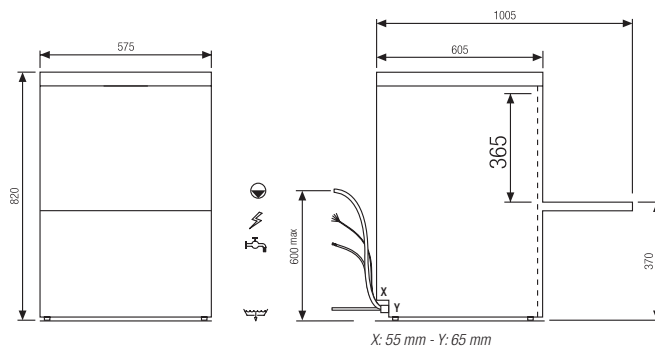
AL260XL



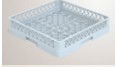



Model - Modelo - Modello	Cod.	€
AL260XL	917852	2.580,00
AL260XLD	917853	2.690,00
AL260XLD (60Hz)	918425	2.640,00

Standard Equipment - Equipamiento - Dotazioni	Cod.
	n. 1 780131
	n. 1 780132
	n. 1 780139

* D: peristaltic detergent dispenser - dosificador de detergente peristáltico - dosatore detergente peristaltico

Technical data - Datos técnicos - Dati tecnici



Dimension - Dimensiones - Dimensioni		cm	57.5x60.5x82
Door opening height - Altura puerta - Apertura porta		cm	36.5
Dish max. height - Altura máxima plato - Altezza max piatto		cm	36.5
Glass max. height - Altura máxima vaso - Altezza max bicchiere		cm	32.5
Washing cycle - Ciclo de lavado - Ciclo di lavaggio		sec.	60 - 120
Rack - Cesta - Cesto		cm	50x50
Water consumption - Consumo de agua - Consumo acqua		L/cycle - L/ciclo - L/ciclo	2.4
Wash pump - Bomba propulsora - Pompa di lavaggio		kW	0.5
		L	20
Tank - Cuba - Vasca		kW	2.1
		°C	60
		L	6
Booster - Calderín - Boiler		kW	4.9
		°C	80
Peristaltic rinse dispenser - Dosificador peristáltico de abrillantador - Dosatore brillantante peristaltico			✓

Optional	Cod.	€	Installed power Potencia instalada - Potenza Installata	Amp.	kW
Drain pump Bomba de desagüe - Pompa scarico	999342	235,00	400 V - 50 Hz - 3N	16	5.4
Detergent dispenser Dosificador de detergente - Dosatore detergente	999347	235,00	400 V - 60 Hz - 3N	16	5.4
Composite tank strainer - Filtro cuba en material compuesto - Filtri vasca in materiale composito	121990	51,00	400 V - 60 Hz - 3N	16	5.4

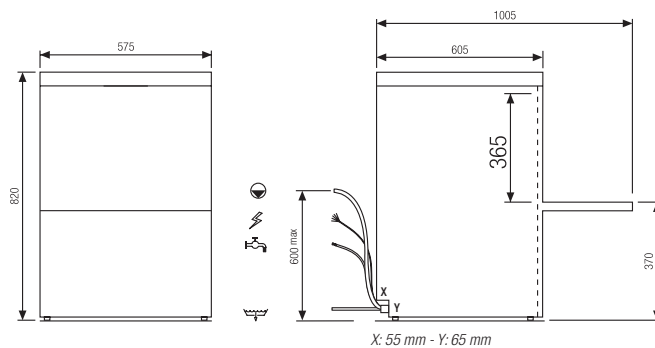
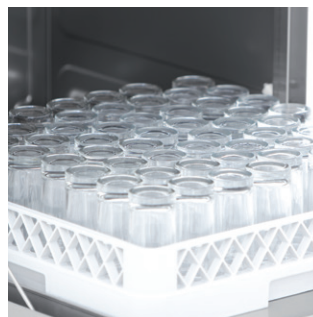
AL260EL



Model - Modelo - Modello	Cod.	€
AL260EL	918444	2.740,00

Standard Equipment - Equipamiento - Dotazioni		Cod.
	n. 1	780131
	n. 1	780132
	n. 1	780139

Technical data - Datos técnicos - Dati tecnici

Dimension - Dimensiones - Dimensioni		cm	57.5x60.5x82
Door opening height - Altura puerta - Apertura porta		cm	36.5
Dish max. height - Altura máxima plato - Altezza max piatto		cm	36.5
Glass max. height - Altura máxima vaso - Altezza max bicchiere		cm	32.5
Washing cycle - Ciclo de lavado - Ciclo di lavaggio		sec.	60 - 120 - 150 - ∞ - 
Rack - Cesta - Cesto		cm	50x50
Water consumption - Consumo de agua - Consumo acqua		L/cycle - L/ciclo - L/ciclo	2.4
Wash pump - Bomba propulsora - Pompa di lavaggio		kW	0.5
		L	20
Tank - Cuba - Vasca		kW	2.1
		°C	60
		L	6
Booster - Calderín - Boiler		kW	4.9
		°C	80
Peristaltic rinse dispenser - Dosificador peristáltico de abrillantador - Dosatore brillantante peristaltico			✓
Peristaltic detergent dispenser - Dosificador peristáltico de detergente - Dosatore detergente peristaltico			✓

Optional	Cod.	€	Installed power Potencia instalada - Potenza Installata	Amp.	kW
Drain pump Bomba de desagüe - Pompa scarico	999342	235,00	400 V - 50 Hz - 3N	16	5.4
Composite tank strainer - Filtro cuba en material compuesto - Filtri vasca in materiale composito	121990	51,00	Available - Disponibile - Disponibile		
			400 V - 60 Hz - 3N	16	5.4
			230 V - 60 Hz - 3	16	5.4

AL280XL

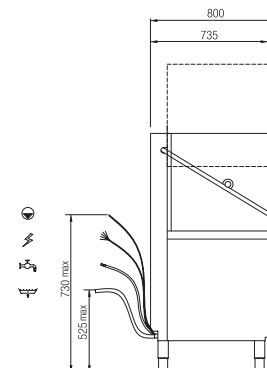
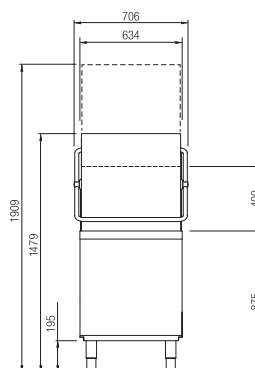

Height - Altura - Altezza: ± 3 cm

Model - Modelo - Modello	Cod.	€	Standard Equipment - Equipamiento - Dotazioni	Cod.
AL280XL	TH50STALK	4.420,00	 n. 1	780131
AL280XL (60Hz)	TH50STALKHZ	4.480,00	 n. 1	780132

Technical data - Datos técnicos - Dati tecnici

Dimension - Dimensiones - Dimensioni		cm	63.5x73.5x148
Door opening height - Altura puerta - Apertura porta		cm	40
Dish max. height - Altura máxima plato - Altezza max piatto		cm	40
Glass max. height - Altura máxima vaso - Altezza max bicchiere		cm	39
Washing cycle - Ciclo de lavado - Ciclo di lavaggio		sec.	60 - 120
Rack - Cesta - Cesto		cm	50x50
Water consumption - Consumo de agua - Consumo acqua		L/cycle - L/ciclo - L/ciclo	2.4
Wash pump - Bomba propulsora - Pompa di lavaggio		kW	0.5
		L	15
Tank - Cuba - Vasca		kW	2.1
		°C	60
		L	6
Booster - Calderín - Boiler		kW	8
		°C	80
Composite tank strainer - Filtro cuba en material compuesto - Filtri vasca in materiale composito			✓
Peristaltic rinse dispenser - Dosificador peristáltico de abrillantador - Dosatore brillantante peristaltico			✓

Optional	Cod.	€	Installed power Potencia instalada - Potenza Installata	Amp.	kW
Drain pump Bomba de desagüe - Pompa scarico	70810	235,00	400 V - 50 Hz - 3N	16	8.5
Drain pump 60Hz Bomba de desagüe 60Hz - Pompa scarico 60Hz	70810Hz	235,00	400 V - 60 Hz - 3N	16	8.5
Detergent dispenser Dosificador de detergente - Dosatore detergente	41954	225,00	Available -Disponibile - Disponibile		
			230 V - 60 Hz - 3	32	8.5

AL280EL

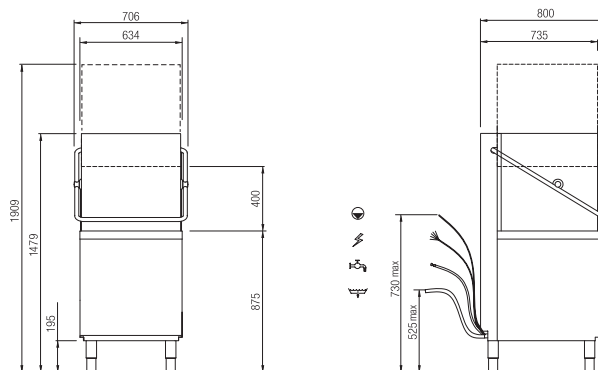

Height - Altura - Altezza: ± 3 cm

Model - Modelo - Modello	Cod.	€
AL280EL	TH50NTALKDD	4.580,00

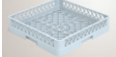



Standard Equipment - Equipamiento - Dotazioni		Cod.
	n. 1	780131
	n. 1	780132

Technical data - Datos técnicos - Dati tecnici





Dimension - Dimensiones - Dimensioni		cm	63.5x73.5x148
Door opening height - Altura puerta - Apertura porta		cm	40
Dish max. height - Altura máxima plato - Altezza max piatto		cm	40
Glass max. height - Altura máxima vaso - Altezza max bicchiere		cm	39
Washing cycle - Ciclo de lavado - Ciclo di lavaggio		sec.	60 - 120 - 150 - ∞ -
Rack - Cesta - Cesto		cm	50x50
Water consumption - Consumo de agua - Consumo acqua		L/cycle - L/ciclo - L/ciclo	2.4
Wash pump - Bomba propulsora - Pompa di lavaggio		kW	0.5
		L	15
Tank - Cuba - Vasca		kW	2.1
		°C	60
		L	6
Booster - Calderín - Boiler		kW	8
		°C	80
Composite tank strainer - Filtro cuba en material compuesto - Filtri vasca in materiale composito			✓
Peristaltic rinse dispenser - Dosificador peristáltico de abrillantador - Dosatore brillantante peristaltico			✓
Peristaltic detergent dispenser - Dosificador peristáltico de detergente - Dosatore detergente peristaltico			✓

Optional	Cod.	€	Installed power Potencia instalada - Potenza Installata	Amp.	kW
Drain pump Bomba de desagüe - Pompa scarico	70810	235,00	400 V - 50 Hz - 3N	16	8.5
Drain pump 60Hz Bomba de desagüe 60Hz - Pompa scarico 60Hz	70810Hz	235,00	Available -Disponibile - Disponibile		
			400 V - 60 Hz - 3N	16	8.5
			230 V - 60 Hz - 3	32	8.5





Tables and accessories for Hood-type
Tablas y accesorios para Lavavajillas de cúpula
Tavoli e accessori per Capot

	Mod.	Dim. (cm)	Cod.	€
	P 70	70x57.5x85	80202	490,00
	PA 70 DX	70x71.5x85	80200	565,00
	PA 70 SX	70x71.5x85	80201	565,00
	PA 120 DX	120x71.5x85	80204	785,00





Tables and accessories for Hood-type
Tablas y accesorios para Lavavajillas de cúpula
Tavoli e accessori per Capot

	Mod.	Dim. (cm)	Cod.	€
	PA 120 SX	120x71.5x85	80203	785,00
	PAL 70 DX	70x71.5x85	80206L700	1.225,00
	PAL 70 SX	70x71.5x85	80205L700	1.225,00
	PAL 120DX	120x71.5x85	80206	1.225,00

Tables and accessories for Hood-type
Tablas y accesorios para Lavavajillas de cúpula
Tavoli e accessori per Capot

	Mod.	Dim. (cm)	Cod.	€
	PAL 120SX	120x71.5x85	80205	1.225,00
	PALS 120 DX	120x71.5x85	80208	1.335,00
	PALS 120 SX	120x71.5x85	80207	1.335,00
	Rubber ring Anillo de goma Anello in gomma		199064	89,00

Tables and accessories for Hood-type
Tablas y accesorios para Lavavajillas de cúpula
Tavoli e accessori per Capot

	Mod.	Dim. (cm)	Cod.	€
	Caster mounted cylindrical garbage Contenedor de basura Pattumiera carrellata in acciaio inox	Ø 40 - h 70	704002	410,00
	Pre-wash shower Ducha Gruppo doccia		799003	355,00
	P60	55,7x57,5x85	69872	210,00
	Open inox plinth Soporte abierto Zoccolo inox aperto (AL260X-AL260E- AL260XL-AL260EL)	57,6x55,6x37,4 H	798005	325,00
	Closed inox plinth Soporte cerrado Zoccolo inox chiuso (AL260X-AL260E- AL260XL-AL260EL)	57,5x56,6x(min38,9-max45,4 H)	798006	385,00

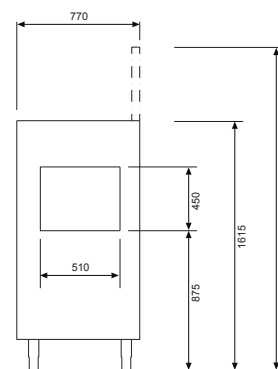
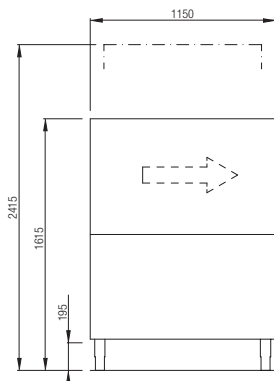
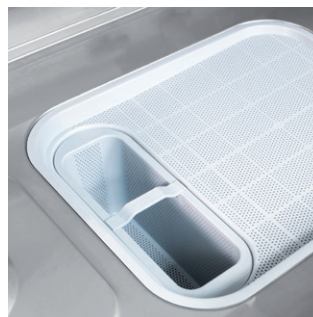

AL101XL





Height - Altura - Altezza: ± 3 cm

Model - Modelo - Modello	Cod.	€
AL101XL (exit rack: R - salida cesta: DCHO - uscita cesto: DX)	T101ALKD	11.580,00
AL101XL (exit rack: L - salida cesta: IZDO - uscita cesto: SX)	T101ALKS	11.580,00
AL101XL (60Hz) (exit rack: R - salida cesta: DCHO - uscita cesto: DX)	T101ALKDHZD	11.930,00
AL101XL (60Hz) (exit rack: L - salida cesta: IZDO - uscita cesto: SX)	T101ALKDHZS	11.930,00

* Available - Disponible - Disponibile: 230V - 60Hz - 3

Standard Equipment - Equipamiento - Dotazioni		Cod.
	n. 1	780072
	n. 1	780135
	n. 1	780139

Technical data - Datos técnicos - Dati tecnici

Dimension - Dimensiones - Dimensioni		cm	77x115x161
Door opening height - Altura puerta - Apertura porta		cm	45
Dish max. height - Altura máxima plato - Altezza max piatto		cm	46
Glass max. height - Altura máxima vaso - Altezza max bicchiere		cm	44
Productivity - Producción - Produttività		rack/h - cesti/h - cestas/h	60 - 120
Rack - Cesta - Cesto		cm	50x50
Water consumption - Consumo de agua - Consumo acqua		L/h	160
Wash pump - Bomba propulsora - Pompa di lavaggio		kW	1.5
		L	70
Tank - Cuba - Vasca		kW	10.5
		°C	60
		L	17
Booster - Calderín - Boiler		kW	9.5 (16-12)
		°C	82
Composite tank strainer - Filtro cuba en material compuesto - Filtri vasca in materiale composito			✓

Installed power Potencia instalada - Potenza Installata	kW	kW (6.55)	kW (9.55)
Maximum power absorption with 50 °C water feed Potencia maxima con agua a 50 °C - Assorbimento massimo con acqua a 50 °C		With dry unit Con módulo secado Con asciugatura	
400 V - 50 Hz - 3N	22	28.55	31.55
Maximum power absorption with 15 °C water feed Potencia maxima con agua a 15 °C - Assorbimento massimo con acqua a 15 °C			
400 V - 50 Hz - 3N	28.5	35.05	38.05
Maximum power absorption with 15 °C water feed and heat recovery system Potencia maxima con agua a 15 °C con recuperador de vahos - Assorbimento massimo con acqua a 15 °C e recuperatore di calore			
400 V - 50 Hz - 3N	24.7	31.25	34.25

Installed power Potencia instalada - Potenza Installata	kW	kW (6.55)	kW (9.55)
Maximum power absorption with 50 °C water feed Potencia maxima con agua a 50 °C - Assorbimento massimo con acqua a 50 °C		With dry unit Con módulo secado Con asciugatura	
400 V - 60 Hz - 3N	22	28.55	31.55
Maximum power absorption with 15 °C water feed Potencia maxima con agua a 15 °C - Assorbimento massimo con acqua a 15 °C			
400 V - 60 Hz - 3N	28.5	35.05	38.05
Maximum power absorption with 15 °C water feed and heat recovery system Potencia maxima con agua a 15 °C con recuperador de vahos - Assorbimento massimo con acqua a 15 °C e recuperatore di calore			
400 V - 60 Hz - 3N	24.7	31.25	34.25

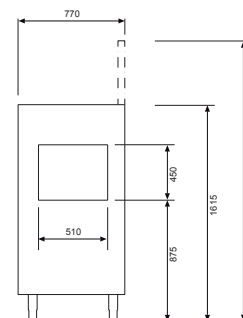
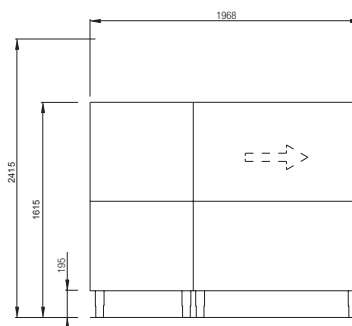

AL102XL







Height - Altura - Altezza: ± 3 cm

Model - Modelo - Modello	Cod.	€
AL102XL (exit rack: R - salida cesta: DCHO - uscita cesto: DX)	T102ALKD	18.820,00
AL102XL (exit rack: L - salida cesta: IZDO - uscita cesto: SX)	T102ALKS	18.820,00
AL102XL (60Hz) (exit rack: R - salida cesta: DCHO - uscita cesto: DX)	T102ALKDHZ	19.170,00
AL102XL (60Hz) (exit rack: L - salida cesta: IZDO - uscita cesto: SX)	T102ALKSHZ	19.170,00

* Available - Disponible - Disponibile: 230V - 60Hz - 3

Standard Equipment - Equipamiento - Dotazioni		Cod.
	n. 1	780072
	n. 1	780135
	n. 1	780139

Technical data - Datos técnicos - Dati tecnici

Dimension - Dimensiones - Dimensioni		cm	77x197x161
Door opening height - Altura puerta - Apertura porta		cm	45
Dish max. height - Altura máxima plato - Altezza max piatto		cm	46
Glass max. height - Altura máxima vaso - Altezza max bicchiere		cm	44
Productivity - Producción - Produttività		rack/h - cesti/h - cestas/h	110 - 200
Rack - Cesta - Cesto		cm	50x50
Water consumption - Consumo de agua - Consumo acqua		L/h	270
Wash pump - Bomba propulsora - Pompa di lavaggio		kW	1.5
Prewash pump - Bomba de prelavado - Pompa di prelavaggio		kW	1.5
Prewash tank - Cuba de prelavado - Vasca di prelavaggio		L	70
Tank - Cuba - Vasca		L	70
		kW	10.5
		°C	60
		L	17
Booster - Calderín - Boiler		kW	15.5 (27-20)
		°C	82
Composite tank strainer - Filtro cuba en material compuesto - Filtri vasca in materiale composito			✓



Installed power Potencia instalada - Potenza Installata	kW	kW (6.55)	kW (9.55)
Maximum power absorption with 50 °C water feed Potencia maxima con agua a 50 °C - Assorbimento massimo con acqua a 50 °C		With dry unit Con módulo secado Con asciugatura	
400 V - 50 Hz - 3N	29.5	36.05	39.05
Maximum power absorption with 15 °C water feed Potencia maxima con agua a 15 °C - Assorbimento massimo con acqua a 15 °C			
400 V - 50 Hz - 3N	41	47.55	50.55
Maximum power absorption with 15 °C water feed and heat recovery system Potencia maxima con agua a 15 °C con recuperador de vahos - Assorbimento massimo con acqua a 15 °C e recuperatore di calore			
400 V - 50 Hz - 3N	34.2	40.75	43.75

Installed power Potencia instalada - Potenza Installata	kW	kW (6.55)	kW (9.55)
Maximum power absorption with 50 °C water feed Potencia maxima con agua a 50 °C - Assorbimento massimo con acqua a 50 °C		With dry unit Con módulo secado Con asciugatura	
400 V - 60 Hz - 3N	29.5	36.05	39.05
Maximum power absorption with 15 °C water feed Potencia maxima con agua a 15 °C - Assorbimento massimo con acqua a 15 °C			
400 V - 60 Hz - 3N	41	47.55	50.55
Maximum power absorption with 15 °C water feed and heat recovery system Potencia maxima con agua a 15 °C con recuperador de vahos - Assorbimento massimo con acqua a 15 °C e recuperatore di calore			
400 V - 60 Hz - 3N	34.2	40.75	43.75

Accessories for Rack-Conveyor

Accesorios para lavavajillas de arrastre

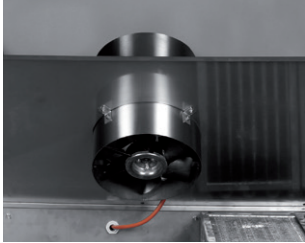

Accessori per Traino

	Mod.	Dim. (cm)	m ³ /h	Volt/kW	Cod.	€
	Line drying zone Módulo de secado Zona asciugatura elettrica	60x77x177.5	1400	400/50/3N 6.55 kW	A	5.175,00
				400/50/3N 9.55 kW	L	5.550,00
	Corner drying zone Módulo de secado en ángulo Zona asciugatura ad angolo	82x87.9x177.5	1400	400/50/3N 6.55 kW	B	10.175,00
				400/50/3N 9.55 kW	I	10.535,00
	Pressure reducer with pressure gauge Válvula reductor de presión Riduttore di pressione	99x82x161			N	315,00
	Exhaust port Collar con aspirador Collarino e aspirazione vapori	Ø 25 - h 21	700	400/50/3N 0.2 kW	E	1.280,00

Accessories for Rack-Conveyor

Accesorios para lavavajillas de arrastre

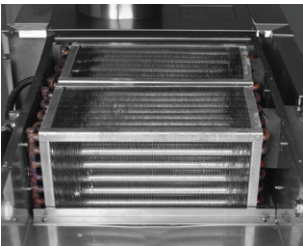

Accessori per Traino

Mod.	Dim. (cm)	m ³ /h	Volt/kW	Cod.	€
 <p>Corner pre-washing Suplemento prelavado en ángulo Prelavaggio ad angolo</p>	99x82x161			P	2.665,00
 <p>Heat recovery Recuperador de vahos Recuperatore calore</p>	Ø 25 - h 21	700	400/50/3N 0.2 kW	R	4.395,00
 <p>Rinse aid and detergent dispenser Dosificadores de detergente y abrillantador Dosatore detersivo e brillantante installato</p>				Y	460,00
 <p>Powered booster Suplemento resistencia calderin Alimentazione ad acqua fredda</p>			9.5 kW	W	345,00

Accessories for Rack-Conveyor

Accesorios para lavavajillas de arrastre



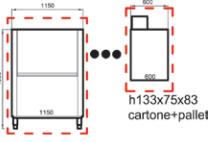
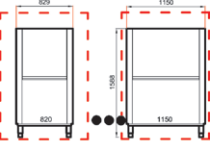
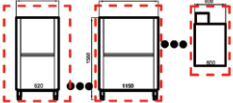

Accessori per Traino

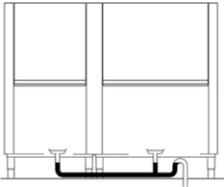
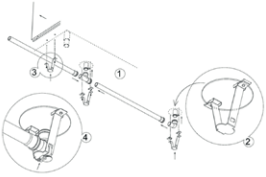
	Mod.	Cod.	€
	<p>End switch for roller table and table kit Kit final de carrera para mesar Kit micro finecorsa per tavoli e rulliere</p>	<p>75861</p>	<p>200,00</p>
	<p>Rinse aid and detergent dispensers kit Kit dosificadores de detergente y abrillantador Kit dosatore detersivo e brillantante installato</p>	<p>65850</p>	<p>490,00</p>
 <p>h185x128x92 cartone+pallet</p> <p>h133x75x83 cartone+pallet</p>	 <p>h185x128x92 cartone+pallet</p> <p>h185x128x92 cartone+pallet</p>	<p>Separate moduls shipment Envío módulos separados Spedizione moduli separati</p> <p>2</p>	<p>930,00</p>
	<p>Separate moduls shipment Envío módulos separados Spedizione moduli separati</p>	<p>3</p>	<p>1.855,00</p>





Accessories for Rack-Conveyor
Accesorios para lavavajillas de arrastre
Accessori per Traino

	Mod.	cm	Cod.	€
	Neutral entry module Cúpula anti-salpicadura Modulo zona neutra in entrata	30x77x161	M	1.300,00
	Drain connection kit for AL101XL kit de conexión de drenaje para AL101XL connessione scarichi per AL101XL		KSCAR11	100,00
	Drain connection kit for AL102XL kit de conexión de drenaje para AL102XL connessione scarichi per AL102XL		KSCAR12	140,00

Accessories for Rack-Conveyor
Accesorios para lavavajillas de arrastre
Accessori per Traino

	Mod.	Dim. (cm)	Cod.	€
	Entry or exit table Mesa entrada salida Piano entrata/uscita	70x70x85	75482	840,00
		110x70x85	75483	870,00
	Exit table with drying module Mesa entrada salida para secado Piano uscita con zona asciugatura	70x70x85	75484	930,00
		110x70x85	75485	960,00
	Mechanized rack-feeding corner unit for right exit machine Mesa esquina mecanizada para máquina salida derecha Piano laterale angolo meccanizzato per macchina uscita DX	60x65x85	75480	2.025,00
	Mechanized rack-feeding corner unit for left exit machine Mesa esquina mecanizada para máquina salida izquierda Piano laterale angolo meccanizzato per macchina uscita SX	60x65x85	75481	2.025,00

Accessories for Rack-Conveyor
Accesorios para lavavajillas de arrastre
Accessori per Traino

	Mod.	Dim. (cm)	Cod.	€
	Sorting table with sink and splashguard for right machine	120x70x85	75451	1.475,00
	Mesa selección con cuba para màquina salida derecha	150x70x85	75452	1.590,00
	Piano di cernita con vasca e azatina per macchina uscita DX	180x70x85	75453	1.690,00
	Sorting table with sink and splashguard for left machine	120x70x85	75456	1.475,00
	Mesa selección con cuba para màquina salida izquierda	150x70x85	75457	1.590,00
	Piano di cernita con vasca e azatina per macchina uscita SX	180x70x85	75458	1.690,00
	Sorting table with sink, dump hole and splashguard for right exit machine	120x70x85	75446	1.680,00
	Mesa selección con cuba, peto y desbrasadado para màquina salida derecha	150x70x85	75447	1.875,00
	Piano di centina con vasca, sbarazzo e alzatina per macchina uscita DX	180x70x85	75448	2.065,00
	Sorting table with sink, dump hole and splashguard for left exit machine	120x70x85	75441	1.680,00
	Mesa selección con cuba, peto y desbrasadado para màquina salida izquierda	150x70x85	75442	1.875,00
	Piano di centina con vasca, sbarazzo e alzatina per macchina uscita SX	180x70x85	75443	2.065,00



Accessories for Rack-Conveyor

Accesorios para lavavajillas de arrastre

Accessori per Traino

	Mod.	Dim. (cm)	Cod.	€
	Straight roller unit with basin and legs with limit switch Rodillos con cuba palatas y final de carrera Rulliera rettilinea con vasca, gambe e fine corsa	110 (114,5)x63x87.5	717066	1.670,00
	A= + 4,5 cm	160 (164,5)x63x87.5	717067	2.205,00
		210 (214,5)x63x87.5	717086	2.925,00
		260 (264,5)x63x87.5	717087	3.615,00
	Mobile roller unit with baffl e-type limit switch Rodillos con cuba palatas sobre ruedas y final de carrera Rulliera mobile con fine corsa	114.5x64x87.5	717069	2.925,00
	A= + 4,5 cm	164.5x64x87.5	717070	3.450,00
		214.5x64x87.5	717088	4.630,00
	90° roller curve with basin and legs Curva con rodillos 90° Curva a rulli a 90° con vasca e gambe	110x110x87.5	717068	2.480,00
	90° machine-moved curve only for unloading Curva mecanizada 90° Curva meccanizzata a 90° per scarico	80x80x87.5	75500	4.495,00

Accessories for Rack-Conveyor
Accesorios para lavavajillas de arrastre
Accessori per Traino

	Mod.	Dim. (cm)	Cod.	€
	180° machine-moved curve only for unloading right exit Curva mecanizada 180° salida derecha Curva meccanizzata a 180° per scarico uscita destra	140x80x87.5	75660DX	7.225,00
	180° machine-moved curve only for unloading left exit Curva mecanizada 180° salida izquierda Curva meccanizzata a 180° per scarico uscita sinistra		75660SX	7.225,00
	Rubber ring Anillo de goma Anello in gomma		199064	89,00

Potwasher
Lavaperolas
Lavaoggetti

AL8XLE

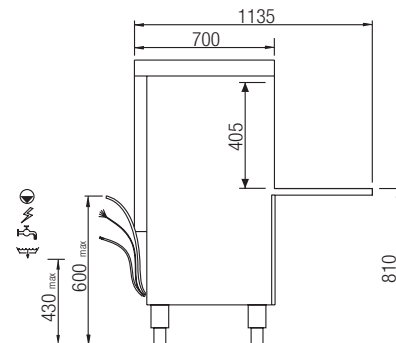
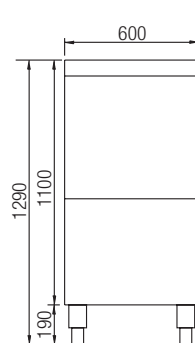

Height - Altura - Altezza: ± 3 cm

Model - Modelo - Modello

Cod.

€

AL8XLE

918526

3.780,00

Standard Equipment - Equipamiento - Dotazioni





Cod.



n. 1

706129

Technical data - Datos técnicos - Dati tecnici

Dimension - Dimensiones - Dimensioni		cm	60x70x129
Door opening height - Altura puerta - Apertura porta		cm	40.5
Washing cycle - Ciclo de lavado - Ciclo di lavaggio		min.	2 - 4 - 8 - ∞
Rack - Cesta - Cesto		cm	50x60
Water consumption - Consumo de agua - Consumo acqua		L/cycle - L/ciclo - L/ciclo	4
Wash pump - Bomba propulsora - Pompa di lavaggio		kW	0.7
		L	23
Tank - Cuba - Vasca		kW	2.1
		°C	60
		L	7
Booster - Calderín - Boiler		kW	6
		°C	80
Tank strainer - Filtro cuba - Filtri vasca			✓

Optional	Cod.	€
Rinse dispenser Dosificador de abrillantador - Dosatore brillantante	999367	235,00
Detergent dispenser Dosificador de detergente - Dosatore detergente	999347	235,00
Drain pump Bomba de desagüe - Pompa scarico	999342	235,00

Installed power Potencia instalada - Potenza Installata	Amp.	kW
400 V - 50 Hz - 3N	16	6.7
Available -Disponibile - Disponibile		
400 V - 60 Hz - 3N	16	6.7

AL9XLE

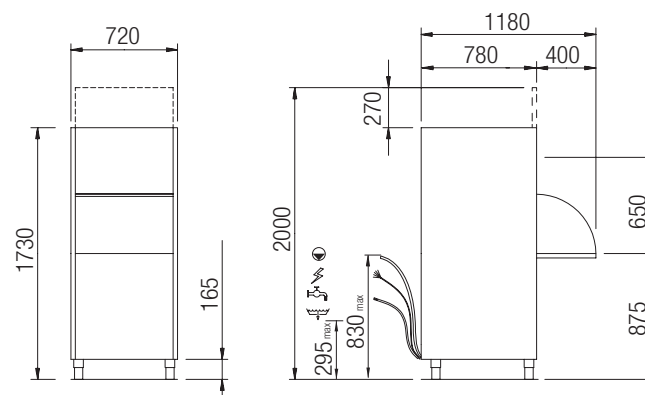
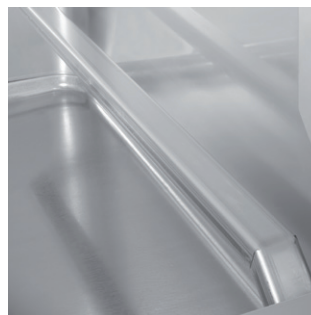

Model - Modelo - Modello

Cod.

€

AL9XLE

LP410ALK

6.420,00

Standard Equipment - Equipamiento - Dotazioni





Cod.



n. 1

41305

Technical data - Datos técnicos - Dati tecnici

Dimension - Dimensiones - Dimensioni		cm	72x78x173
Door opening height - Altura puerta - Apertura porta		cm	65
Washing cycle - Ciclo de lavado - Ciclo di lavaggio		min.	2 - 4 - 8 - ∞
Rack - Cesta - Cesto		cm	56x63
Water consumption - Consumo de agua - Consumo acqua		L/cycle - L/ciclo - L/ciclo	4
Wash pump - Bomba propulsora - Pompa di lavaggio		kW	1.5
		L	37
Tank - Cuba - Vasca		kW	3
		°C	55
		L	6
Booster - Calderín - Boiler		kW	6
		°C	80
Tank strainer - Filtro cuba - Filtri vasca			✓

Optional	Cod.	€
Rinse dispenser Dosificador de abrillantador - Dosatore brillantante	67950	225,00
Detergent dispenser Dosificador de detergente - Dosatore detergente	67954	225,00
Drain pump Bomba de desagüe - Pompa scarico	67610	235,00

Installed power Potencia instalada - Potenza Installata	Amp.	kW
400 V - 50 Hz - 3N	16	7.5
Available -Disponibile - Disponibile		
400 V - 60 Hz - 3N	16	7.5

AL9HXLE

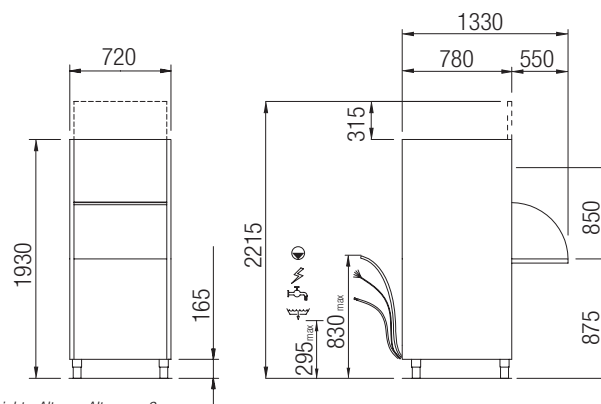





Height - Altura - Altezza: ± 3 cm

Model - Modelo - Modello	Cod.	€
AL9HXLE	LP510ALK	7.590,00

Standard Equipment - Equipamiento - Dotazioni	Cod.
 n. 1	41305

Technical data - Datos técnicos - Dati tecnici

Dimension - Dimensiones - Dimensioni		cm	72x78x193
Door opening height - Altura puerta - Apertura porta		cm	85
Washing cycle - Ciclo de lavado - Ciclo di lavaggio		min.	2 - 4 - 8 - ∞
Rack - Cesta - Cesto		cm	56x63
Water consumption - Consumo de agua - Consumo acqua		L/cycle - L/ciclo - L/ciclo	4
Wash pump - Bomba propulsora - Pompa di lavaggio		kW	1.5
		L	37
Tank - Cuba - Vasca		kW	3
		°C	55
		L	6
Booster - Calderín - Boiler		kW	6
		°C	80
Tank strainer - Filtro cuba - Filtri vasca			✓

Optional	Cod.	€
Rinse dispenser Dosificador de abrillantador - Dosatore brillantante	67950	225,00
Detergent dispenser Dosificador de detergente - Dosatore detergente	67954	225,00
Drain pump Bomba de desagüe - Pompa scarico	67610	235,00

Installed power Potencia instalada - Potenza Installata	Amp.	kW
400 V - 50 Hz - 3N	16	7.5
Available -Disponibile - Disponibile		
400 V - 60 Hz - 3N	16	7.5



Rack and accessories



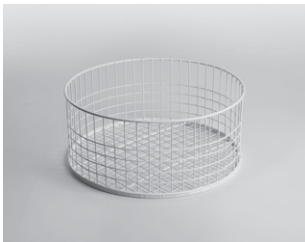
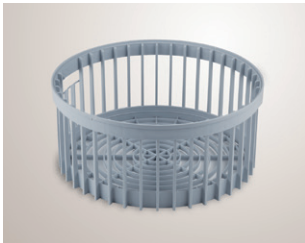
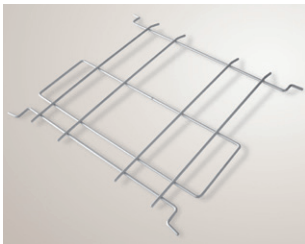

Cestas y accesorios

Cesti e accessori



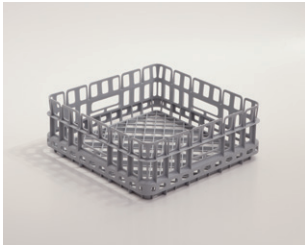

Rack Cestas Cesti

	Mod.	Dim. (cm)	(cm)	Cod.	€
	Square plat rack for glasses Cesta cuadrada de varilla Cesto bicchieri quadrato fondo piano	35x35x15		983063	53,00
		39x39x10		983055	53,00
		39x39x15		983056	55,00
	Round rack Cesto redondo de varilla Cesto bicchieri rotondo	Ø 35 - h 11		706095	55,00
		Ø 35 - h 16.5		706107	63,00
		Ø 39 - h 11		983060	63,00
		Ø 39 - h 16.5		983015	63,00
	Round rack Cesto redondo Cesto bicchieri rotondo	Ø 35		706147	60,00
		Ø 39		706148	66,00
	Round rack adapter Adaptador para cesta redonda Griglia supporto cesto tondo (AL230x)	Ø 35		433030	33,00
	Round rack adapter Adaptador para cesta redonda Griglia supporto cesto tondo (AL240x)	Ø 39		433031	33,00





Rack Cestas Cesti

	Mod.	Dim. (cm)	(cm)	Cod.	€
	Square sloping rack 4 rows Cesta quadra con fondo inclinado 4 filas Cesto bicchieri quadrato 4 file fondo inclinato	39x39x17	Ø 8.5	983038	80,00
	Square sloping rack 3 rows Cesta quadra con fondo inclinado 3 filas Cesto bicchieri quadrato 3 file fondo inclinato	39x39x17	Ø 11	983041	76,00
	Glass rack close mesh Cesta vasos Cesto bicchieri quadrato fondo piano	35x35x11		780138	50,00
		39x39x15		780133	66,00
	Standard small dish insert Insertador para platos Inserto inclinado universale per piattini	30.5 x 9 x 7.5	n. 13	712020	23,00





Rack Cestas Cesti

	Mod.	Dim. (cm)	(cm)	Cod.	€
	Square dishes rack Cesta platos de varilla Cesto piatti quadrato	45x45	n. 14 - Ø 24	983067	80,00
	Square plat rack for glasses Cesta cuadrada de varilla Cesto bicchieri quadrato fondo piano	45x45x10		983068	77,00
	Glass rack Cesta vasos Cesto bicchieri	45x45x10.6		780128	66,00
	Dish rack Cesta platos Cesto piatti	45x45x10.6		780129	66,00



Rack Cestas Cesti

	Mod.	Dim. (cm)	(cm)	Cod.	€
	Square rack Cesta de varilla Cesto quadro	50x50x15		983032	80,00
	Square sloping rack 6 rows Cesta quadra con fondo inclinado 5 filas Cesto bicchieri quadrato 5 file fondo inclinato	50x50x17	n. 14 - Ø 24	983082	100,00
	Square dishes rack Cesta platos de varilla Cesto piatti quadrato	50x50	n. 18 - Ø 24 n. 8 - Ø 33	983027	74,00
	Square cutlery rack Cesta quadra para cubiertos Cesto posate quadrato	50x50		983033	106,00

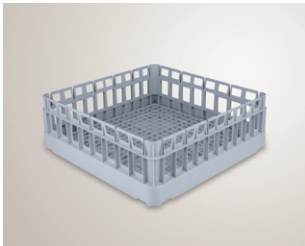
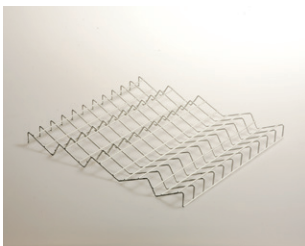

Rack Cestas Cesti

	Mod.	Dim. (cm)	(cm)	Cod.	€
	Flat rack close mesh Cesta vasos Cesto posate	50x50		780080	71,00
	Cesta para platos pizza Plate rack for pizza dishes Cesti piatti pizza	50x50	n. 9 - Ø 38	780074	81,00
	Tray rack Cesta para bandejas Cesto vassoi	50x50	n. 6 - 53x37	780106	83,00
	Tray rack Cesta para bandejas Cesto vassoi	50x50	n. 4 - 53x37	780077	160,00

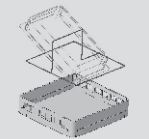

Rack Cestas Cesti

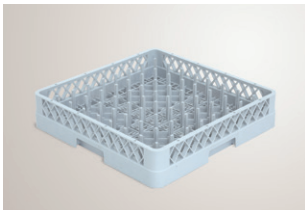
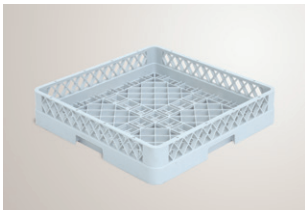
	Mod.	Dim. (cm)	(cm)	Cod.	€	
	Dish rack Cesta platos Cesto piatti	50x50	n. 18 - Ø 24	780072	68,00	
	Glass rack Cesta vasos Cesto bicchieri	50x50		780135	66,00	
	Sloping cup insert for rack 780135 Parrilla insertador para tazas para cesta 780135 Inserto inclinatore tazze per cesto 780135			780082	42,00	
	Inox insert for Gastronorm GN1/1 (53x32x10 cm) Insertador inox para Gastronorm GN1/1(53x32x10 cm) Inserto inox per Gastronorm GN1/1 (53x32x10 cm)		only for rack conveyor para lavavajillas de arrastre per lavastoviglie a traino		67908	100,00

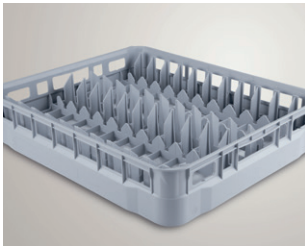
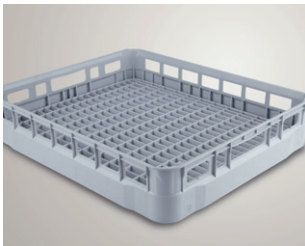
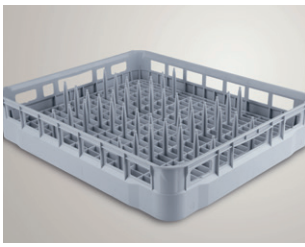

Rack Cestas Cesti

	Mod.	Dim. (cm)	Cod.	€
	Dish rack - not usable for rack conveyor Cesta platos - no para lavavajillas de arrastre Cesto piatti - non adatto per modelli a traino	50x50	780131	54,00
	Glass rack - not usable for rack conveyor Cesta vasos - no para lavavajillas de arrastre Cesto bicchieri - non adatto per modelli a traino	50x50	780132	54,00
	Cutlery insert Contenedor de cubiertos Cestello porta posate	11x11x14	780139	15,00
	4 division cutlery insert Contenedor de cubiertos de 4 compartimentos Inserto posate a 4 divisioni	21.7x21.7x13.4	780081	34,00

Rack Cestas Cesti

	Mod.	Dim. (cm)	Cod.	€
	Dish rack Cesta platos Cesto piatti	50x60 n.22 - Ø 31	70180	122,00
	Glass rack Cesta vasos Cesto bicchieri	50x60	70181	122,00
	Tray rack Cesta para bandejas Cesto vassoi	50x60	70182	122,00
	Inox rack (for AL8XLE) Cesto acero (for AL8XLE) Cesto inox (for AL8XLE)	50x60	706129	235,00



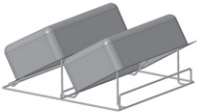
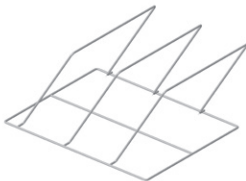
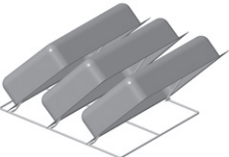

Rack Cestas Cesti

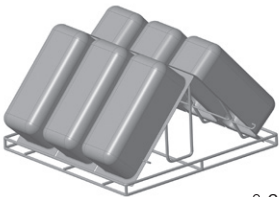
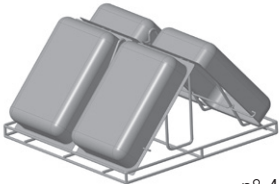
	Mod.	Dim. (cm)	Cod.	€
	Inox rack (for AL9XLE - AL9HXLE) Cesta acero (por AL9XLE - AL9HXLE) Cesto inox (per AL9XLE - AL9HXLE)	56x63	41305	255,00
	Rack with top cover (not for AL8XLE) Cesta con tapa en la parte superior (no para AL8XLE) Cesto portaoggetti con coperchio (non per AL8XLE)		67905	525,00
	Inox insert for Gastronorm GN1/1 (53x32x10-15-20 cm) Insertador inox para Gastronorm GN1/1 (53x32x10-15-20 cm) Inserto inox per Gastronorm GN1/1 (53x32x10-15-20 cm)		for AL9XLE - AL9HXLE 67906	140,00
	Inox insert for Gastronorm GN1/1 (53x32x10 cm) Insertador inox para Gastronorm GN1/1 (53x32x10 cm) Inserto inox per Gastronorm GN1/1 (53x32x10 cm)		for AL9XLE - AL9HXLE 67907	140,00

Rack Cestas Cesti

	Mod.	Dim. (cm)	Cod.	€
	Inox insert for ice cream boxes (VG33 - VG36), no for 8XLE Inserto para cajas de helado (VG33 - VG36), no para 8XLE Inserto inox per vaschette gelato (VG33 - VG36), no per 8XLE		67909	250,00
 n° 6	VG33168 VG331612 VG331615 VG36168 VG361612 VG361615	330x165x80h 3,5 L 330x165x120h 5,0 L 330x165x150h 6,5 L 360x165x80h 3,8 L 360x165x120h 5,4 L 360x165x150h 7,1 L		
 n° 4	VG36258 VG362512	360x250x80h 5,0 L 360x250x80h 8,0 L		





Rack Cestas Cesti

	Mod.	Dim. (cm)	(cm)	Cod.	€
	Inox insert for funnel and sac à poche Insertador en embudo para confitería Inserto inox per imbuti e sac à poche	Ø 17		706128	56,00
	Inox insert for 8 tray for tray 4 cm deep Soporte para 8 bandejas Profundidad máxima de la bandeja 4 cm Telaio inox per 8 teglie profondità max 4 cm	50x50		H.324660	180,00
	Inox insert for 5 tray for tray 6.5 cm deep Soporte para 5 bandejas Profundidad máxima de la bandeja 6.5 cm Inserto inox per 5 teglie profondità max 6.5 cm	50x50		712028	212,00
	Inox insert for cutlery and utensils Contenedor de cubiertos Contenitore inox per posate ed utensili	15x15		712017	77,00





Detergent dispenser and drain pump
Dosificador de detergente y bomba de desague
Dosatori e detergenti

Mod.		Cod.	€
 <p>Drain pump kit Kit bomba de desagüe Kit pompa scarico</p>	AL230X - AL240X - AL240E	999354	195,00
	AL250X	999357	235,00
	AL260X - AL260E - AL260XL - AL260EL - AL8XLE	999342	235,00
	AL280XL - AL280EL	70810	235,00
	AL9XLE - AL9HXLE	67610	235,00
	60 Hz Drain pump kit 60 Hz Kit bomba de desagüe 60 Hz Kit pompa scarico	AL280XL - AL280EL	70810 Hz
 <p>Detergent dispenser kit Kit dosificador de detergente Kit dosatore detergente</p>	AL230X-AL240X-AL240E-AL250X- AL260X-AL260E AL260XL-AL260EL	999347	235,00
	AL280XL - AL280EL AL9XLE - AL9HXLE	67954	225,00
 <p>Rinse aid dispenser kit Kit dosificadores de abrillantador Kit dosatore brillantante</p>	AL8XLE	999367	235,00
	AL9XLE - AL9HXLE	67950	225,00



Water softner Suavizador Addolcitore

	Mod.	Dim. (cm)	Cod.	€
	Manual water softner 8L Suavizador manual 8L Addolcitore manuale 8L	24 x 19 x 42	708001	148,00
	Manual water softner 12L Suavizador manual 12L Addolcitore manuale 12L	24 x 19 x 42	708002	164,00
	Manual water softner 16L Suavizador manual 16L Addolcitore manuale 16L	24 x 19 x 62	708003	212,00
	Manual water softner 20L Suavizador manual 20L Addolcitore manuale 20L	24 x 19 x 71	708004	255,00

Detergents
Detergencia
Detergenza

	Mod.	Cod.	€
	<p>PRO RINSE H</p> <p>Rinse-aid for hard water (6 liters can - box of 3 cans) Abillantador para el agua dura (caja de 6 litros - 3 bidónes) Brillantante per acque dure (scatola da 3 taniche - taniche da 6 l)</p>	131352	120,00
	<p>PRO RINSE B</p> <p>Rinse-aid for soft water (6 liters can - box of 3 cans) Abillantador para el agua blanda (caja de 6 litros - 3 bidónes) Brillantante per acque dolci (scatola da 3 taniche - taniche da 6 l)</p>	131351	105,00
	<p>PRO RINSE O</p> <p>Rinse-aid for demineralized water (6 liters can - box of 3 cans) Abillantador para el agua desmineralizada (caja de 6 litros - 3 bidónes) Brillantante per acque demineralizzate (scatola da 3 taniche - taniche da 6 l)</p>	131355	165,00
	<p>PRO WASH H</p> <p>Liquid detergent for hard water (6 liters can - box of 3 cans) Detergente líquido para el agua dura (caja de 6 litros - 3 bidónes) Detersivo liquido per acque dure (scatola da 3 taniche - taniche da 6 l)</p>	131353	120,00

Detergents
Detergencia
Detergenza

	Mod.	Cod.	€
	<p>PRO WASH B</p> <p>Liquid detergent for soft water (6 liters can - box of 3 cans) Detergente líquido para el agua blanda (caja de 6 litros - 3 bidónes) Detersivo liquido per acque dolci (scatola da 3 taniche - taniche da 6 l)</p>	131350	105,00
	<p>PRO WASH 0</p> <p>Liquid detergent for demineralized water (6 liters can - box of 3 cans) Detergente líquido para el agua desmineralizada (caja de 6 litros - 3 bidónes) Detersivo liquido per acque demineralizzate (scatola da 3 taniche - taniche da 6 l)</p>	131354	140,00

Attrezzaturearredi si riserva il diritto di apportare ai prodotti le migliorie, sia meccaniche che estetiche, senza alcun preavviso.

a1

www.attrezzaturearredi.it

ITALIA

attrezzature  **arredi**
EXPERIENCE EXPERTISE

Via Roberto Bronzetti, 10 - 47922 Rimini (RN)

T. 0541/1781030 - 3 LINEE R.A.

commerciale@attrezzaturearredi.it - www.attrezzaturearredi.it